

NOTES:

- ALL DOORS INCLUDE FACTORY PRE-MACHINING FOR HARDWARE.
- ALL DOORS INCLUDE FACTORY SEALING OF EDGES
- FACTORY PRE-FINISHING IS OPTIONAL.
SPECIFIED FACTORY FINISH TO BE: _____.

LEGEND:

1. WOOD FACE VENEER (PULL SIDE).
FACE VENEER TO BE: _____.
2. WOOD FACE VENEER (PUSH SIDE).
FACE VENEER TO BE: _____.
3. ACOUSTIC CORE.
4. HARDWOOD STILES AND RAILS.
5. SWEEP SEAL.
6. 1/4" HIGH FLAT ACOUSTIC THRESHOLD.
7. FINISHED FLOOR COVERING MATERIAL.

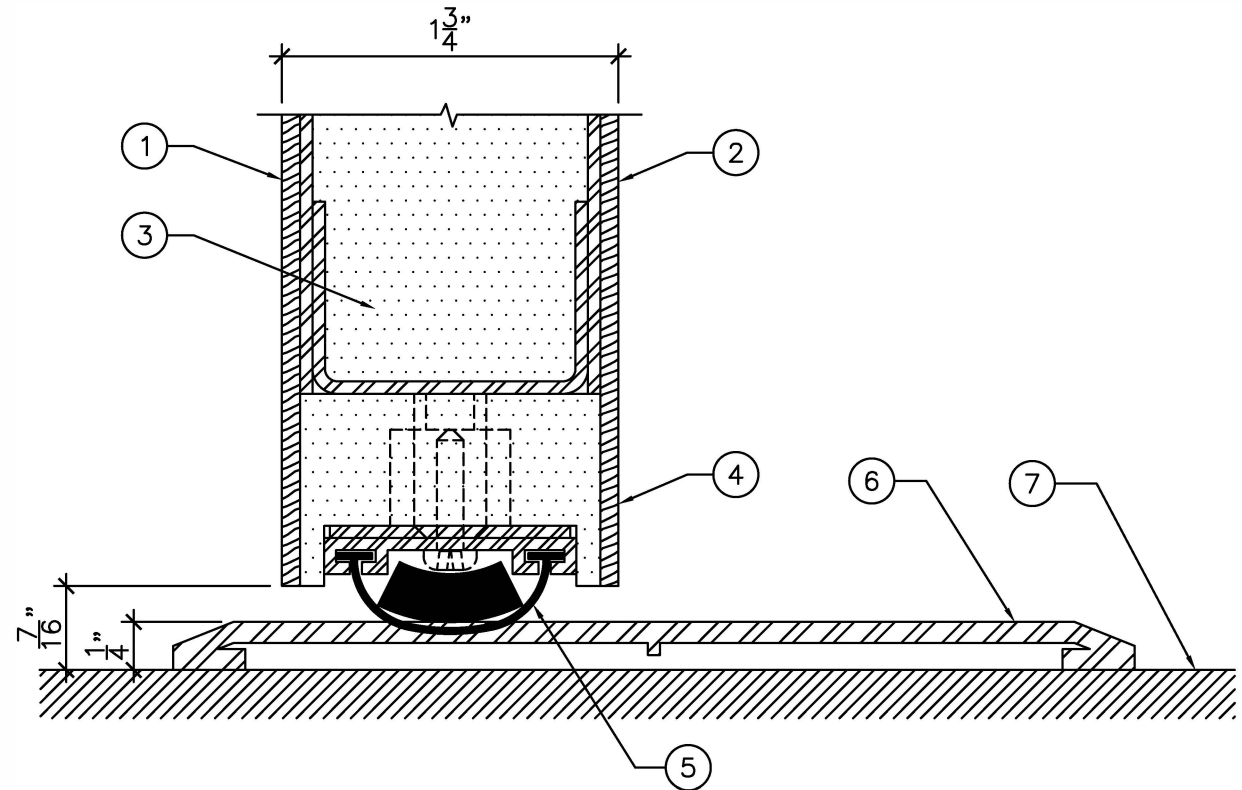

ELEVATION (PULL SIDE - LH/RHR SHOWN)

3/4" = 1'-0"

BOTTOM DETAIL "A"

1"-0" = 1'-0"



DRAWING TITLE:

**WOOD CLAD ACOUSTIC DOOR - NON FIRE RATED
FROM STC 41 TO STC 46**

DATE:

DRAWN BY:

REVISION:

0