

LEGEND:

1. "INACTIVE" ACOUSTIC DOOR.
2. "ACTIVE" ACOUSTIC DOOR.
3. ACOUSTIC MEETING STILE ASTRAGAL SEAL.
4. SOFT FOAM.
5. REMOVABLE SEAL RETAINER (ALUMINUM).
6. SEAL BRACKET (STEEL).

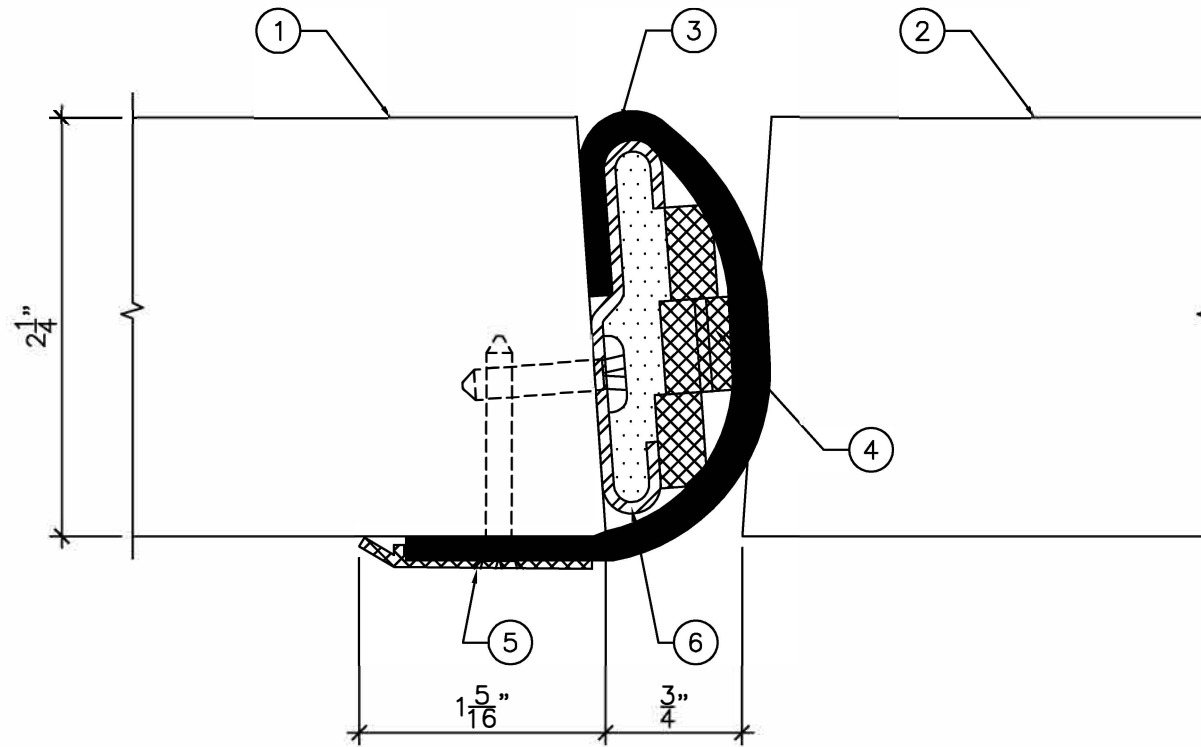

ASTRAGAL SECTION
1'-0" = 1'-0"



DRAWING TITLE:

ASTRAGAL, 2.25' THICK WOOD AND STEEL DOORS, BOTH ACTIVE
STC 33 TO STC 50

DATE:

DRAWN BY:

REVISION:

0