

LEGEND:

1. "INACTIVE" ACOUSTIC DOOR.
2. "ACTIVE" ACOUSTIC DOOR.
3. ACOUSTIC MEETING STILE ASTRAGAL SEAL.
4. SOFT FOAM.
5. INTUMESCENT.
6. REMOVABLE SEAL RETAINER (ALUMINUM).
7. SEAL BRACKET (STEEL).

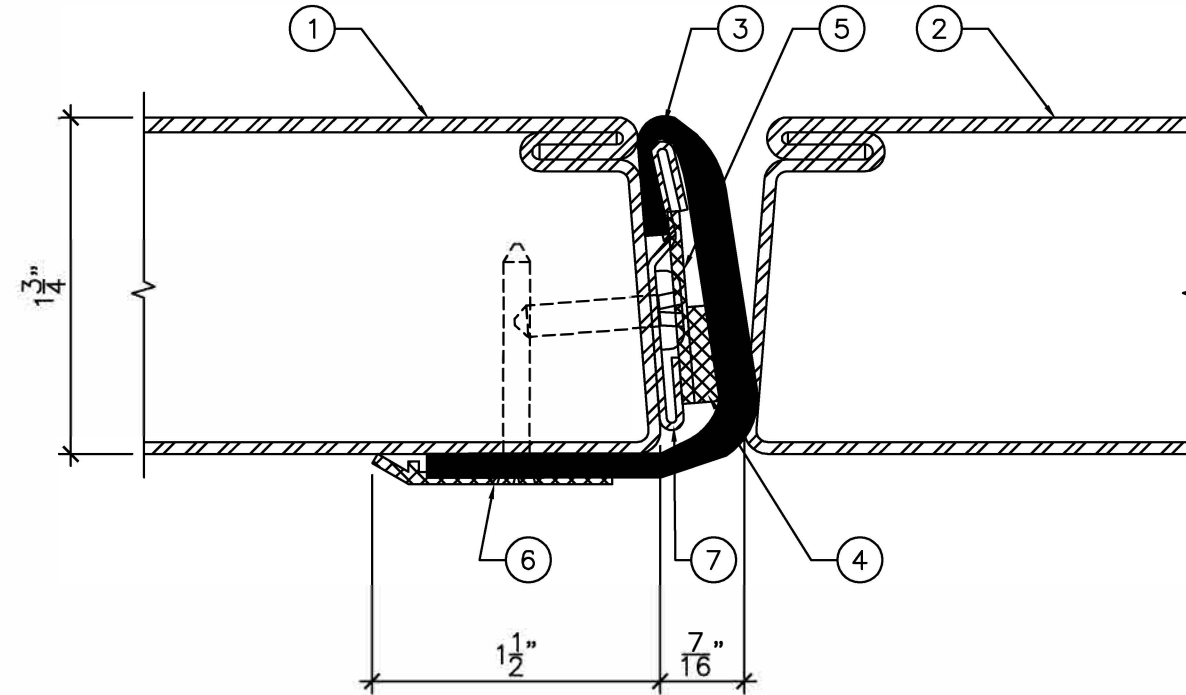

ASTRAGAL SECTION
1'-0" = 1'-0"



DRAWING TITLE:

**ASTRAGAL, 1.75" THICK STEEL DOORS, BOTH ACTIVE, FIRE RATED
STC 33 TO STC 50**

DATE:

DRAWN BY:

REVISION:

0