

FOR STC 52 RATING MAX AREA  
OF CUTOUT = 345 SQ.IN.

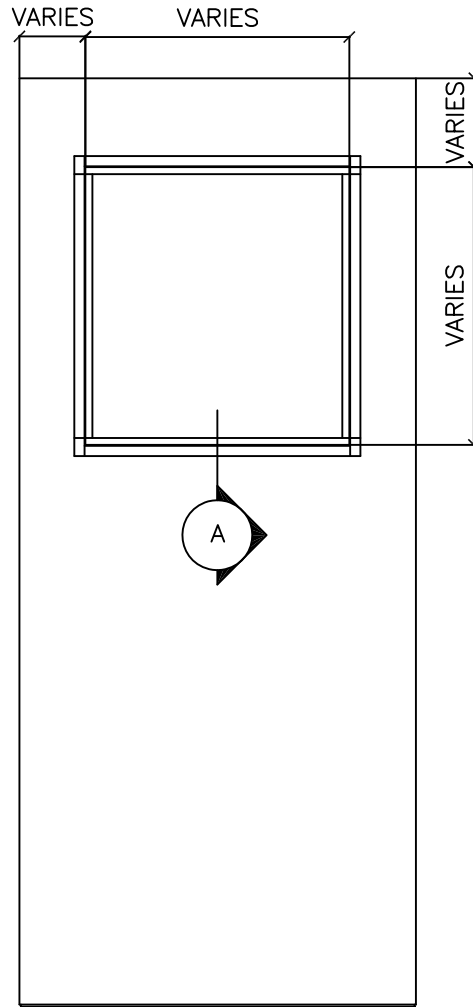

**SECTION "A"**  
3/4" = 1'-0"

LEGEND:

1. ACOUSTIC GLASS
2. FIXED STOP ON THE SECURE SIDE (LOCK CYLINDER SIDE) OF THE DOOR.
3. REMOVABLE STOP C/W #10 FH SCREWS.
4. ALL VOIDS FILLED WITH SOUND DEADENER.

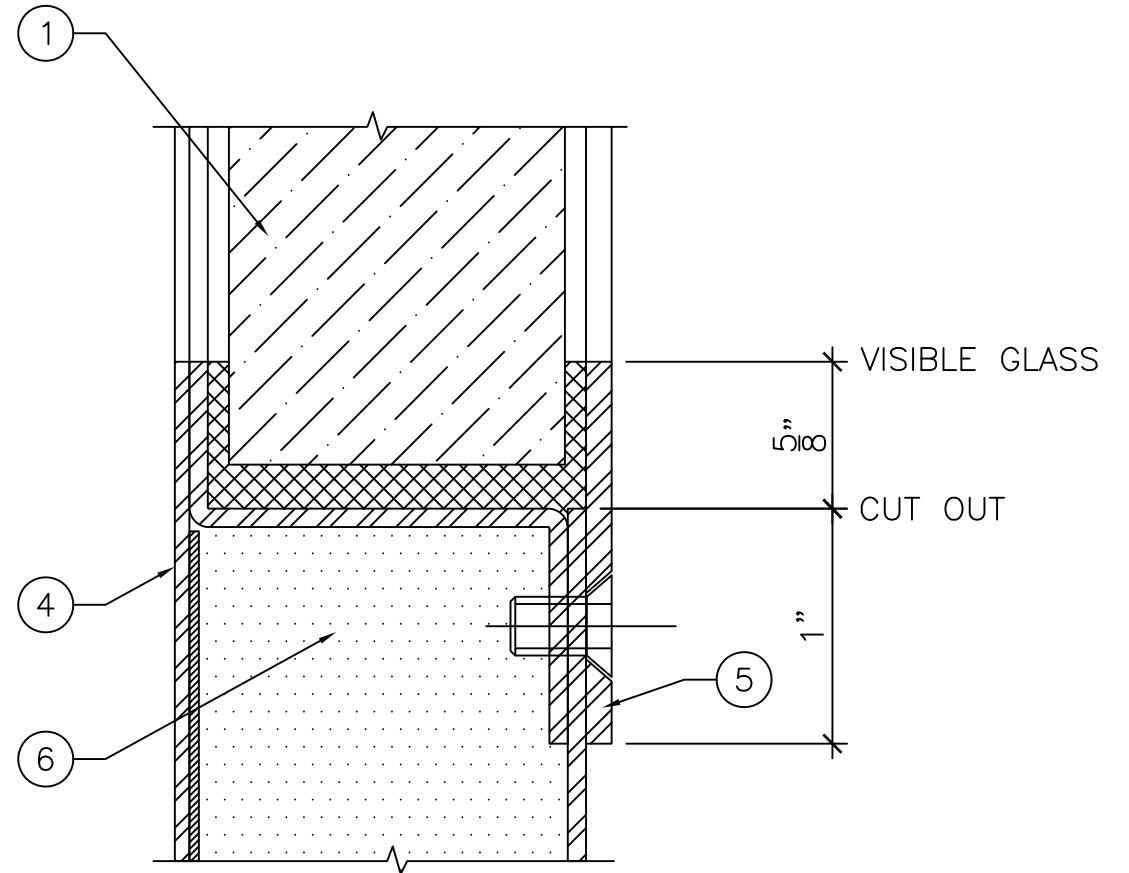

**SECTION "A"**  
1'-0" = 1'-0"

CONSULT AMBICO FOR ADDITIONAL  
LITE KIT DESIGNS



DRAWING TITLE:

**STEEL ACOUSTIC DOOR WITH LITE KIT**  
**STC 49 TO STC 52**

DATE:

DRAWN BY:

REVISION:

0