

PRODUCTS STANDARDS:

FRAMES SHALL BE TEMPLATED, REINFORCED AND DRILLED & TAPPED FOR MORTISED HARDWARE. ALL REINFORCING SHALL BE THE SAME MATERIAL AND FINISH AS THE CORE FRAME. DRILLING & TAPPING FOR SURFACE APPLIED HARDWARE SHALL BE BY OTHERS. FRAMES SHALL BE SHIPPED WITH TEMPORARY SPREADERS FOR SUPPORT DURING SHIPPING. THESE ARE NOT TO BE A SUBSTITUTE FOR SQUARING OR PLUMBING OF FRAMES DURING INSTALLATION. FRAMES SHALL BE SHIPPED WITH BUMPERS TO BE MOUNTED ON STOPS (3 ON A SINGLE & 2 ON DOUBLES), WALL ANCHORS, AND FLOOR CLIPS. FLOOR CLIPS WILL BE OMITTED WITH EXISTING WALL ANCHORS. HEADER AND JAMBS TO BE MECHANICALLY FASTENED USING A BUTT JOINT CONNECTION.

DETAIL "A"

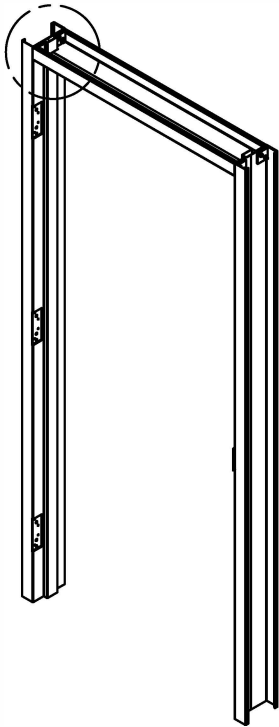

PRODUCTS OPTIONS:

FRAME CORE

MATERIAL

- o 16 GA. GALVANNEALED STEEL
- o 16 GA. 304 STAINLESS STEEL
- o 16 GA. 316 STAINLESS STEEL

CLADDING

BRONZE/BRASS MATERIALS & FINISHES¹ MATERIALS

- o 0.050" C220 BRONZE
- o 0.050" C230 RED BRASS
- o 0.050" C280 MUNTZ BRASS
- o 0.050" C385 ARCHITECTURAL BRONZE

FINISHES²

- o BRUSHED
- o POLISHED

STAINLESS STEEL MATERIALS & FINISHES¹ MATERIALS

- o 18 GA. 304 STAINLESS
- o 18 GA. 316 STAINLESS

FINISHES²

- o 2B, NOT PAINTED
- o #4
- o #6
- o #7
- o #8 XL BUFF
- o #8 SUPREME
- o XL BLEND S
- o XL SUEDE

FRAME CONSTRUCTION

- o BUTT JOINT³

¹ MATERIALS AND FINISHES ARE TYPICAL. CONSULT AMBICO FOR ADDITIONAL OPTIONS.

² SOME FINISHES MAY NOT BE POSSIBLE BASED ON HARDWARE. CONSULT AMBICO FOR INFORMATION.

³ MECHANICALLY FASTENED.

GENERAL NOTES

— ALL GRAINED FINISHES SHALL HAVE VERTICAL GRAIN IN JAMBS AND VERTICAL MULLIONS AND HORIZONTAL GRAIN IN HEADS, SILLS AND HORIZONTAL MULLIONS. INTERSECTING MULLIONS, MULLIONS AND PERIMETERS AND CONNECTIONS BETWEEN UNEQUAL FACE DIMENSIONS SHALL HAVE VISIBLE BUTT JOINT CONNECTIONS.

ISOMETRIC

3/4" = 1'-0"

DRAWING TITLE:

CLAD FRAME SPECIFICATION SHEET 1 OF 2



DATE:

DRAWN BY:

REVISION:

0

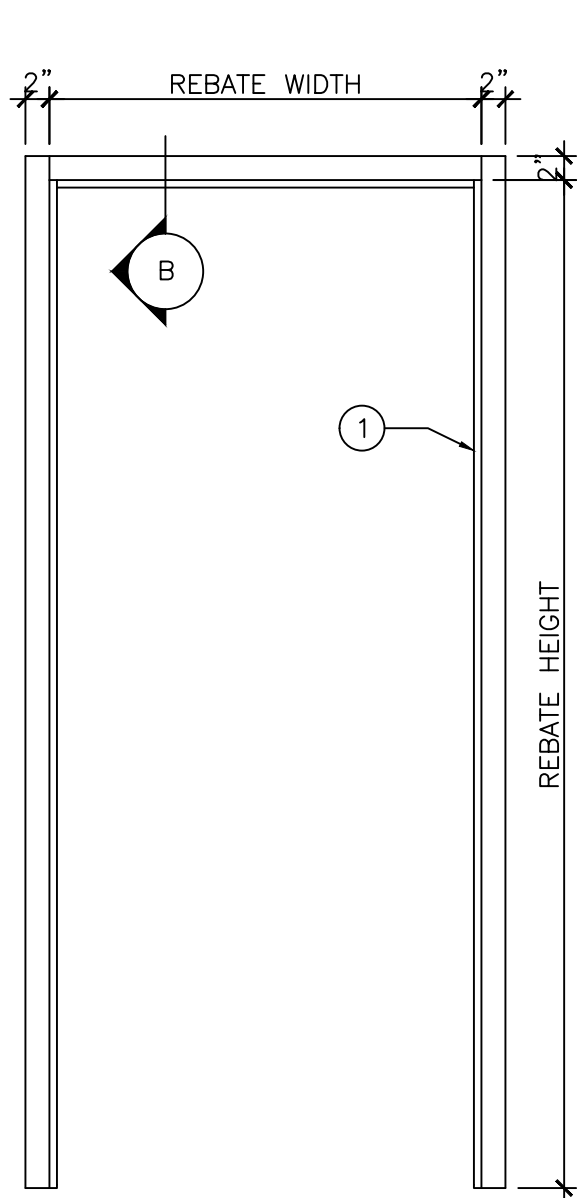

ELEVATION
3/4" = 1'-0"

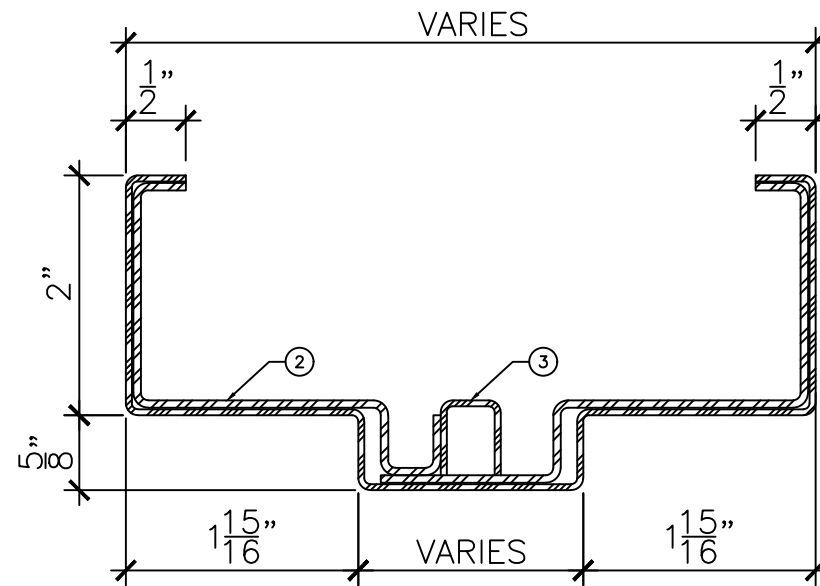

DOUBLE REBATE DETAIL "B"
1"-0" = 1'-0"

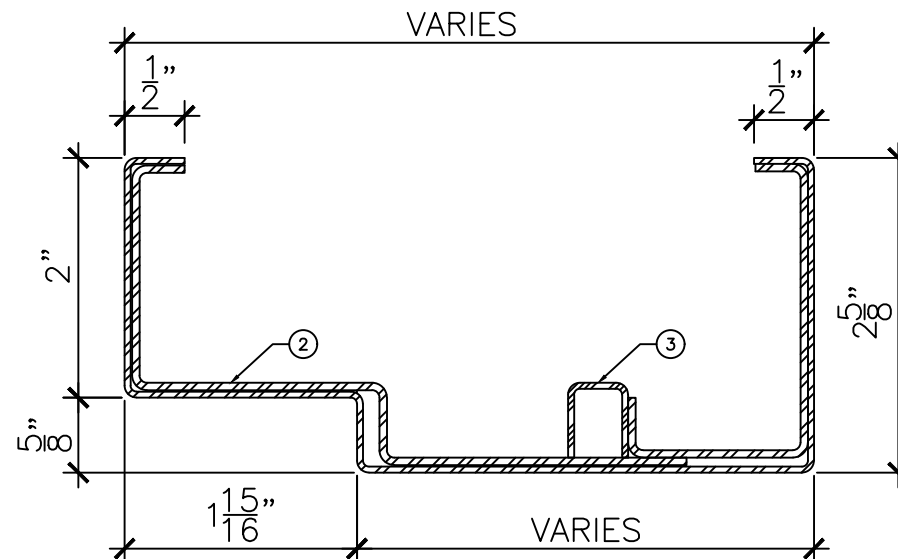

SINGLE REBATE DETAIL "B"
1"-0" = 1'-0"

- LEGEND:
1. CLAD FRAME.
 2. FRAME CORE.
 3. GLAZING BEAD.

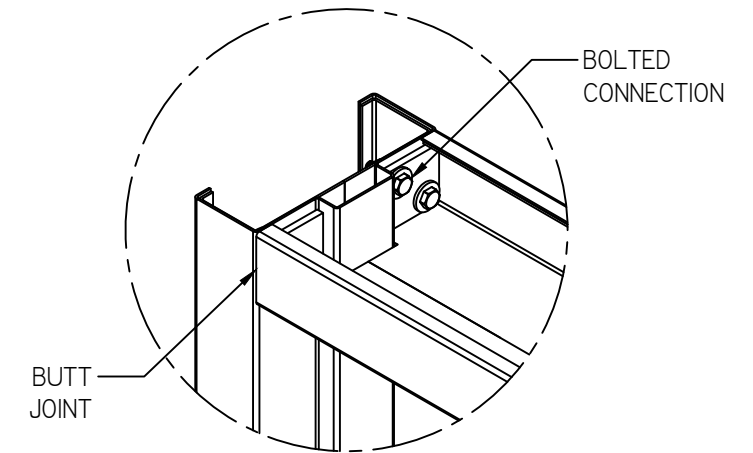

DETAIL "A"
1"-0" = 1'-0"



DRAWING TITLE:
CLAD FRAME SPECIFICATION SHEET 2 OF 2

DATE:	MARCH 7, 2017
DRAWN BY:	TWB
REVISION:	0