

ELEVATION
 $\frac{3}{4}'' = 1'-0''$

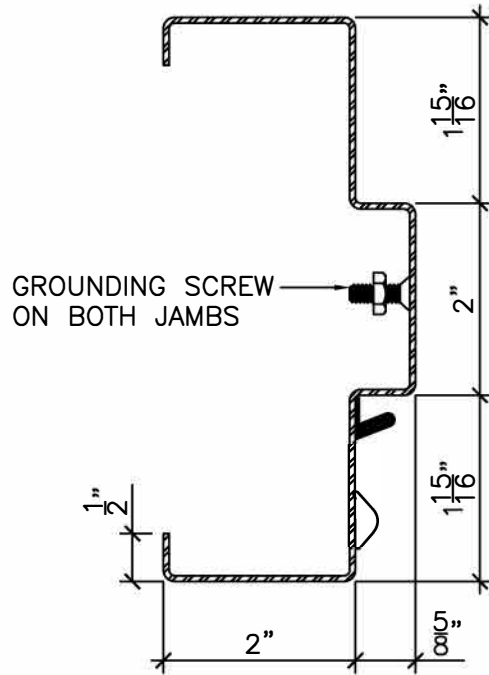

SECTION "A"
 $6'' = 1'-0''$

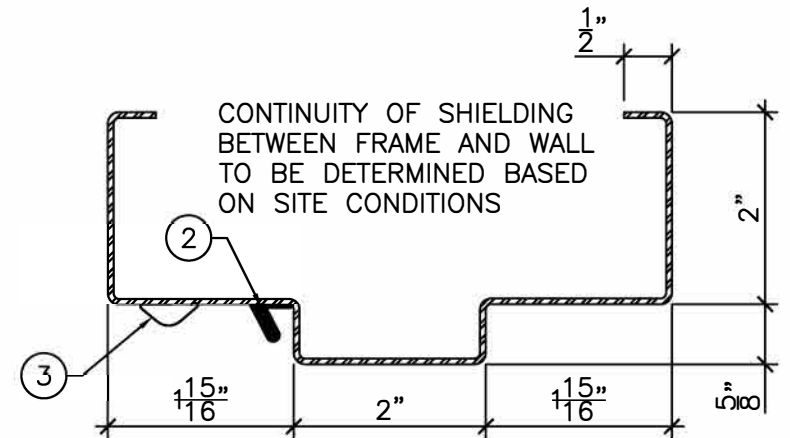

SECTION "B"
 $6'' = 1'-0''$

LEGEND:

1. PRESSED STAINLESS STEEL FRAME WITH FULLY WELDED MITERED CORNERS TO BE INSTALLED AT TOP LEVEL OF FLOOR COVERING MATERIAL BY INSTALLER.
2. RF FOAM SEALS TO BE FIT AND APPLIED BY INSTALLER ON SITE.
3. RF FINGERSTOCK SEALS TO BE FIT AND APPLIED BY INSTALLER ON SITE.

NOTES:

- CAM-LIFT HINGES SUPPLIED BY AMBICO.
- ENTIRE FRAME/DOOR ASSEMBLY TO BE ELECTRICALLY GROUNDING.



DRAWING TITLE:

40 dB RF-SHIELDED FRAME

DATE:

DRAWN BY:

REVISION: